

Undertake Projects,  
Choose Hengwang,  
Prosper in Business!

干工程 选恒旺 事业兴旺



## 山东恒旺集团有限公司

Shandong Hengwang Group Co., Ltd.

- Ⓒ 山东省济宁市任城区金宇西路4号海能国际C座24层  
Floor 24, Building C, Haineng International, No. 4 Jinyu West Road, Rencheng District, Jining City, Shandong Province
- 🌐 [www.hengwang.cn](http://www.hengwang.cn)
- ☎ 400-9975-666
- ✉ [info@hengwang.cn](mailto:info@hengwang.cn)



## CRAWLER EXCAVATOR 履带挖掘机 HW380

- ⊙ 工作重量 Working weight: 37T
- ⊙ 额定功率 Rated power: 241KW
- ⊙ 挖斗容积 Bucket capacity: 1.8m<sup>3</sup>

恒旺集团  
HENGWANG GROUP

恒旺集团  
HENGWANG GROUP

干工程 选恒旺 事业兴旺

Undertake Projects, Choose Hengwang  
Prosper in Business!

恒旺集团  
HENGWANG GROUP

恒旺集团  
HENGWANG GROUP

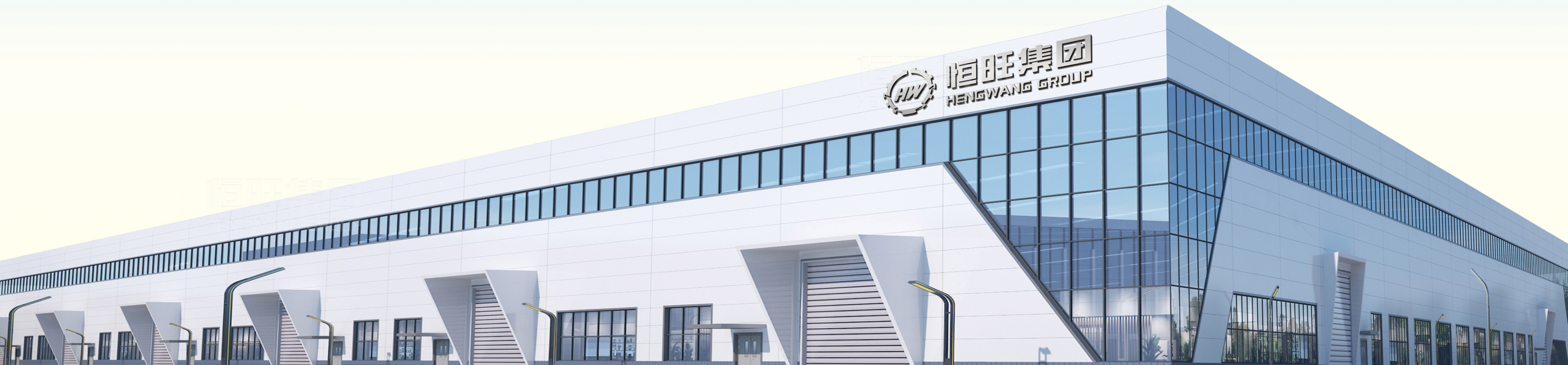

# 卓越的性能， 完全满足各类用户需求。

Excellent performance, fully  
Meet the needs of various users.

HW380 履带式挖掘机，适用于市政工程、土石方工程、园林绿化、道路修缮、水泥混凝土的破碎、河道清淤、林场抓木、工程钻孔、混凝土整平、装卸货物等各种工程作业环境，可迅速更换各种作业属具，整机配置挖斗、破碎锤、旋转抓、螺旋钻、振动夯、电吸盘等多种属具，满足客户多种工程需求，更换方便、操作简单。

HW380 crawler excavator is suitable for various engineering operation environments such as municipal engineering, earthwork engineering, landscaping, road repair, cement concrete crushing, river dredging, forest wood grabbing, engineering drilling, concrete leveling, loading and unloading of goods, etc. It can quickly replace various operating accessories. The whole machine is equipped with a variety of accessories such as bucket, breaker, rotary grab, auger, vibratory rammer, electric suction cup, etc. to meet customers' various engineering needs. It is easy to replace and simple to operate.



恒旺集团  
HENGWANG GROUP

HEWANG

# PRODUCT UPGRADE BRAND NEW EXPERIENCE

## 产品升级 全新体验

### 液压系统 Hydraulic system

搭载负载敏感系统变量柱塞泵，进口液压系统，整机敏感度更高，响应速度更快，实现发动机/泵/阀高效匹配，整机作业综合能效比提升。

Equipped with load-sensing system variable plunger pump and imported hydraulic system, the whole machine has higher sensitivity and faster response speed, realizes efficient matching of engine/pump/valve, and improves the overall energy efficiency ratio of the whole machine operation.

### 行走系统 Walking system

液压挖掘机采用履带式行走机构，能够在各种复杂地形下灵活行驶，具有出色的机动性和适应性。行走系统还具有稳定性好、承载能力强等特点，能够适应各种工作环境。

The hydraulic excavator adopts a crawler-type traveling mechanism, which can run flexibly in various complex terrains, and has excellent maneuverability and adaptability. The walking system also has the characteristics of good stability and strong carrying capacity, and can adapt to various working environments.

### 驾驶室 Driver's cab

驾驶室内部配备倒车影像、电子显示屏，行驶更安全；驾驶室前方一体玻璃，可以随时提放，视野开阔，私密性好，噪音更低；太空座椅，大大缓解驾驶员的疲劳状态；冷暖空调更舒适；风扇、音响一应俱全。

The interior of the cab is equipped with a reversing image and an electronic display screen, making driving safer; the integrated glass in front of the cab can be lifted and placed at any time, with a wide field of view, good reliability, and lower noise; the space seat greatly relieves the fatigue of the driver; Heating and cooling air conditioners are more comfortable; fans and audio are all available.

### 动力系统 Power system

搭载康明斯43 6LTA8.9.C325高功率 241KW 发动机，动力输出更稳定，整机操作动作更流畅，油耗低、动力足、扭矩大、好维修。

Equipped with Cummins 43 6LTA8.9.C325 high power 241KW engine, the power output is more stable, the whole machine operates more smoothly, with low fuel consumption, sufficient power, high torque and good maintenance.

可根据客户要求，定制更换加长臂，增大挖掘高度，增加挖掘深度，机身更换相对应铸铁配重。

Customization of extended arms, increased digging height, and increased digging depth can also be done according to customer requirements, with corresponding cast iron counterweights replacing the machine body.

## 灵活高效 全面能手

Flexible and efficient all-rounder



松土器 Scarifier



抓木器 Wood grabber



拇指夹 Thumb clip



破碎锤 Hammer



机器耙 Machine rake



螺旋钻 Auger



窄挖斗 Narrow bucket



翻斗 Tipping bucket

## 精工细作 品质保证

Fine workmanship, quality assurance



发动机 Engine



行走马达 Walking motor



座椅 Seat



散热器 Heat sink



钢履带 steel tracks



高清显示屏 HD display



回转马达 Rotary motor



回转支承 Slewing ring

## 技术参数

Machine detailed parameters

### 发动机 Engine

发动机 Engine	康明斯(Cummins) 43 6LTA8.9.C325	
主泵 Main pump	川崎 Kawasaki	
主阀 Main valve	川崎 Kawasaki	
发动机（整机）功率 Engine (whole machine) power	241/2000	kw/rpm
发动机最大扭矩 Engine maximum torque	1080Nm/1500rpm	N.m/rpm
发动机最大转速 Engine maximum speed	2000	rpm

### 液压系统 Hydraulic System

液压系统压力 Hydraulic system pressure	36	Mpa
液压系统额定流量 Rated flow of hydraulic system	330	L/min

### 加注容量和润滑油 Refilling Capacities & Lubrications

燃油箱容积/实际容积 Fuel tank capacity/actual capacity	580	L
液压箱容积 Hydraulic tank capacity	310	L

### 挖掘力 Digging Force

铲斗挖掘力 Bucket digging force	230	KN
斗杆挖掘力 Arm digging force	190	KN

### 出行系统 Travel System

行走速度（实际） Travel speed (actual)	5.0/3.0	Km/h
最大牵引力 Maximum traction	280	KN
爬坡能力 Grade climbing ability	35	%
行走马达 Travel motor	斗山 Doosan	

### HENGWANG 摆动系统 Swing System

转速 (实际) Speed (actual)	9.7	rpm
旋转扭矩 Rotational torque	130019N.m	KNm

### 铲斗 Bucket

铲斗容量 Bucket Capacity	1.8	m <sup>3</sup>
----------------------	-----	----------------

### 重量和接地压力 Weight and grounding pressure

总重 Total weight	37500	kg
接地电压 Ground voltage	62	Kpa

### 其他配置 Other configurations

ECU	OK
机器控制单元 (车身控制模块) Machine control unit (BCM)	OK
附件管路+蓄能器 Accessory lines + accumulators	OK
液压回路回油滤清器 Hydraulic circuit return filter	OK
后视摄像头 Rearview camera	OK
空调 Air conditioning	OK

### 工作尺寸 Working size

最大挖掘半径 Maximum digging radius	10540	mm
最大地面挖掘半径 Maximum ground digging radius	10540	mm
最大挖掘深度 Maximum digging depth	6780	mm
最大垂直挖掘深度 Maximum vertical digging depth	6210	mm
最大挖掘高度 Maximum digging height	10210	mm
最大卸载高度 Maximum dumping height	7280	mm
最小转弯半径 Minimum turning radius	4350	mm

### 机器尺寸 Machine size

动臂长度 Boom length	6470	mm
斗杆长度 Arm length	2740	mm
总长 Overall length	11320	mm
总宽 Overall width	3340	mm
总高 Overall height	3610	mm
登车宽度 Board width	3195.3	mm
驾驶室宽度 Cab width	1000	mm
尾部转弯半径 Tail turning radius	3550	mm
最小离地间隙 Minimum ground clearance	540	mm
轴距 Wheelbase	2740	mm
轨距 Track gauge	2740	mm
履带宽度 Track width	600	mm

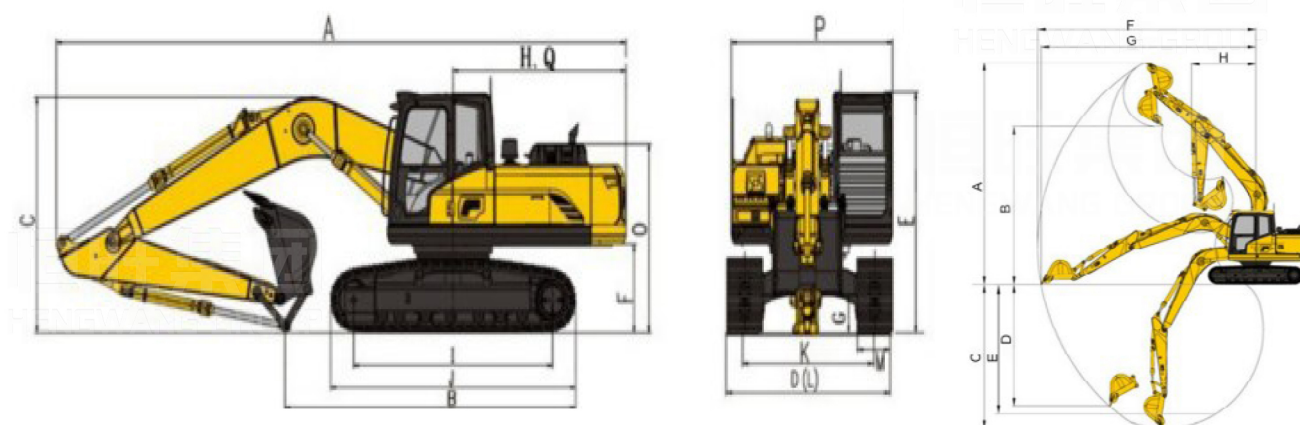

注: 图片和参数仅供参考, 由于技术不断更新, 材料和技术规范如有更改, 恕不另行通知, 照片上的机器可能包括附加设备, 具体配置请咨询业务员。

Note: Pictures and parameters are for reference only. Due to constant technological updates, materials and technical specifications are subject to change without prior notice. The machine in the photo may include additional equipment. Please consult the salesperson for specific configurations.

## 维修和保养

### Maintenance and repair



## 便捷保养

### Convenient Maintenance

电气件集中安装，打开前盖板即可维护，操作方便。

覆盖件采用全钢件，经久耐用可回收。

采用大面积覆盖件开启方式，打开后可站在地面进行日常维护和保养，维修方便、接近性好。

空气滤清器、油水分离器、燃油滤、机油滤、保险盒等触手可及，保养十分方便。

润滑脂加注：黄油加注口布置挖机同侧，润滑保养更方便。

散热器：外部专设护网，脏物被挡在护网外侧，只需将护网拆下清洗即可。

The electrical components are installed centrally, and the maintenance can be done by opening the front cover, which is easy to operate.

The cover is made of all steel, which is durable and recyclable.

It adopts the opening method of the large-area cover. After opening, it can stand on the ground for daily maintenance and maintenance. It is convenient for maintenance and good in accessibility.

The air filter, oil-water separator, fuel filter, engine oil filter, fuse box, etc. are within easy reach, making maintenance very convenient.

Grease filling: The grease filling port is arranged on the same side of the excavator, which is more convenient for lubrication and maintenance.

Radiator: There is a special protective net on the outside, and the dirt is blocked outside the protective net. You only need to remove the protective net for cleaning.

## 售后服务

### After sales service



#### 24 小时热线 24 Hours Telephone

您有任何需要，只需要拨打 24 小时售后服务热线 400-9975-666。

If you have any needs, just call the 24-hour after-sales service hotline 400-9975-666.



#### 15 分钟回复 15 Minutes To Respond

接到售后需求后，售后服务工程师将主动和您取得联系，向您了解设备情况和服务需求，通过电话，微信视频等远程指导处理问题。After receiving the after-sales demand, the after-sales service engineer will take the initiative to get in touch with you, ask you about the equipment situation and service needs, and deal with the problem through remote guidance such as telephone and WeChat video.



#### 24 时出发 24 hours departure

若电话指导无法处理好故障，服务工程师在 24 小时内携带维修工具出发，前往设备所在现场，进行现场维修服务。

If the telephone guidance cannot handle the fault well, the service engineer will set off with the maintenance tools within 24 hours, go to the site where the equipment is located, and perform on-site maintenance services.



#### 重大情况处理 Handling of major situations

重大和特殊情况，服务体系将启动快速反应机制、专家支持机制和配件绿色通道。

In major and special circumstances, the service system will start a rapid response mechanism, an expert support mechanism and a green channel for accessories.



#### 电话回访 Telephone interviews

现场服务完工后，公司总部呼叫中心将有服务专员对每次服务进行电话回访，跟踪完成情况和 service 质量，听取客户意见和建议并反馈到各职能部门进行落实和改善，以便为客户提供更优质的售后服务。

After the on-site service is completed, the call center of the company's headquarters will have a service specialist to conduct a return call for each service, track the completion status and service quality, listen to customer opinions and suggestions, and feed back to each functional department for implementation and improvement, so as to provide customers with better quality.



卓越的性能  
完全满足各类用户需求  
Excellent performance Fully meeting various user needs



高新技术企业  
High-tech enterprises

全国机械行业文明单位  
National Model Unit in the Machinery Industry

全国煤炭机械工业优秀企业  
National Outstanding Enterprise in Coal Machinery Industry

对外贸易重点入库企业  
Key Enterprise in Foreign Trade Database

中国工程机械工业协会会员单位  
Member Unit of the China Construction Machinery Industry Association

## COMPANY PROFILE

### 公司介绍

山东恒旺集团 创立于 2011 年，注册资金一亿元，坐落于运河之都、孔孟之乡的中国文化名城——山东济宁。历经十余年的发展，现已发展成为一家集设计研发、生产制造、国际贸易、电子商务、网络服务、物流运输为一体的创新科技企业。厂区占地面积 10 余万平方米，现有员工 1000 余人。2024 年 10 月，总投资 10.1 亿元人民币、占地面积 20 余万平方米的恒旺机械装备智能化生产基地，在济北高新技术产业园落成并投产。

以研发之长，领技术之先。恒旺依托科技创新，依据市场发展和客户需求，不断研发出各种新型实用机械设备。当前主营产品覆盖挖掘机、推土机、钻探机械、光伏打桩机、压路机、装载机、吊车、叉车、履带运输车等 40 多个品类，产品畅销全球 180 多个国家和地区。

恒旺集团自成立初期就构建了较为完备、多元化的市场经营体系和产业价值链。在恒旺集团发展的十余年中，始终坚持立足本土，内强研发，外拓海外，摸索出一条适合自身发展的“互联网+传统制造业”的创新之路，跻身跨境电商新型产业模式之中，迈上持续快速发展的新台阶和跨越式发展的新时代。

恒旺始终践行“创新驱动、质量为先”的发展理念，全面推进产品升级。在智能化改装领域持续取得突破，远程操控已成功应

用于多种钻桩设备，施工安全得到真正保障；挖掘机领域突破多项技术难题，不断推出各种新型挖改设备，全力帮助客户实现一机多用，从而实现更高收益。

一直以来，恒旺集团不断加快知识产权标准化建设，重视培养、培育人才，以管理创新、技术创新推动公司持续发展。在坚持自主创新的道路上，先后获得各类专利 200 余项。精雕细琢，品质卓然，并先后通过 ISO、欧盟 CE、法国 BV 等十余项质量、安全检测等项目认证。

信誉为上，服务为本。通过多年的客户服务实践，恒旺建立起产品体验、用户培训、维修保障、配件供应“四维一体”的一站式服务体系并持续完善，为客户提供一体化施工解决方案，人性化、智能化的优质服务得到广大客户的一致好评和认可。

恒旺秉承“持恒心、守恒德、做恒业”的核心价值观，致力于让最广泛的客户享受最高性价比的产品和服务，朝着“建百年企业，创百年品牌”的发展方向不断前行。

干工程，选恒旺，事业兴旺！

Shandong Hengwang Group founded in 2011 with a registered capital of 100 million RMB, is located in Jining, Shandong, a renowned cultural city known as the Capital of the Grand Canal and the hometown of Confucius and Mencius. After more than a decade of development, It has now developed into an innovative technology enterprise integrating technology research and development, production, international trade, e-commerce, network services, and logistics transportation. The factory area covers more than 100,000 square meters, and it currently has over 1,000 employees. In October 2024, Hengwang Machinery's Intelligent Manufacturing Base, with a total investment of 1.01 billion RMB and covering an area of over 200,000 square meters, was completed and put into production in the Jibei High-Tech Industrial Park.

With the strength of R & D and leading in technology, Hengwang relies on technological innovation, guided by market development and customer needs, to continuously develop various new and practical machinery equipment. The current main products cover more than 40 categories including excavators, bulldozers, drilling machinery, new energy piling machines, road rollers, loaders, cranes, forklifts, crawler transporters, etc. The products are exported to more than 180 countries and regions.

Since its establishment, Hengwang Group has built a comprehensive and diversified market operation system and industrial value chain. In the more than ten years of development, Hengwang has always adhered to the strategy of local focus, strengthening research and development, expanding overseas markets, and exploring an innovative path of "Internet + traditional manufacturing". It has entered the new model of cross-border e-commerce and embarked on a new era of sustained rapid development and leapfrog development.

Hengwang always adheres to the development philosophy of "innovation-driven, quality first" and comprehensively promotes product upgrades.

It has made continuous breakthroughs in intelligent transformation and remote control technology, ensuring construction safety. In the field of excavators, it has solved multiple technical problems and continuously introduced various new excavation equipment, helping customers achieve multiple uses and higher profits.

Hengwang Group has been actively promoting the standardization of intellectual property rights and has attached great importance to talent cultivation and training. Through management innovation and technological innovation, it has driven the company's sustainable development. Accumulated more than 200 patents of various types over time. It has also passed more than ten quality and safety certification projects such as ISO, EU CE, and France BV.

With reputation as the top priority and service as the foundation, Hengwang has established a one-stop service system integrating product experience, user training, maintenance support, and spare parts supply through years of customer service practice. It provides customers with integrated construction solutions and has received unanimous praise and recognition for its humanized and intelligent high-quality service.

Adhering to the core values of perseverance, integrity, and dedication, Hengwang is committed to providing the widest range of customers with the highest cost-effective products and services, and continuously advances towards the direction of establishing a century-old brand and creating a first-class corporate culture.

Undertake Projects, Choose Hengwang, Prosper in Business!